

OLYMPIC MIXED DOUBLE-HANDED OFFSHORE KEELBOAT
SUN FAST 3300 PROPOSAL

Topics

- The Group
- History of the range
- Sun Fast 3300 characteristics
- Rating certificates
- Velocity prediction
- Race results
- Offshore abilities
- Mixed double-handed
- Technical approach
- Distribution
- Events
- Awards
- Testimonials
- Video

SUN FAST 3300



SUN FAST 3300

The Group :

- For over 135 years, across the generations, Groupe Beneteau's men and women have cultivated their passion in boating.
- With its international production capacities and global sales networks, the Group operates 19 marine production sites and employs 8,326 people worldwide.
- Through its Boat division's 12 brands, Groupe Beneteau offers 224 recreational boat models. In 2018-19, the Group's brands launched 38 new models.
- With 1.143 B€ revenues in 2018-19 in the boating division, the Group continues to grow, and reinforces its world's leadership position in the sailboat industry.
- For over 60 years, Jeanneau has designed, produced and sold an extensive selection of sailboat, yacht, outboard and inboard models around the world.
- Today, Jeanneau is one of the major brands of the Group.



GRUPE BENETAU



SUN FAST 3300

History of the range :

- Jeanneau's involvement into sailboat racing dates back to the eighties, with the glorious years of "Jeanneau Techniques Avancées" with 3 boats built by Jeanneau on the 1990 Route du Rhum podium !
- The Sun Fast range was born in 1993, and initially concentrated on inshore racer-cruiser (16 different models designed in 14 years).
- In 2007, Jeanneau anticipated market changes, and decided to dedicate the range to IRC short-handed offshore racing.
- The Sun Fast 3200 was the first boat based on this concept, and achieved huge success in regattas and commercially. The Sun Fast 3600 followed in 2014. Overall, more than 300 Sun Fast 3200 and 3600 are sailing worldwide...
- In 2019, the Sun Fast 3300 replaced the 3200. Based on this long experience and extensive feedback of racing sailors, this 19th Sun Fast continues the tradition of highly-competitive short-handed and offshore aspects.

1982 Exclusive supplier of the Sailing Tour de France / Fournisseur exclusif du Tour de France



1984 Construction of the Fleury Michon 7 / Construction du Fleury Michon 7 (25.90m)



1990 A triple victory for Jeanneau / Une triple victoire pour Jeanneau



1991 Jeanneau One design



1993 1st Sun Fast / 1st Sun Fast



2014 18th model of the range ! / 18^e modèle de la gamme !



2019

Nouvelle génération de Sun Fast / New Sun Fast generation

SUN FAST
3300

SUN FAST 3300

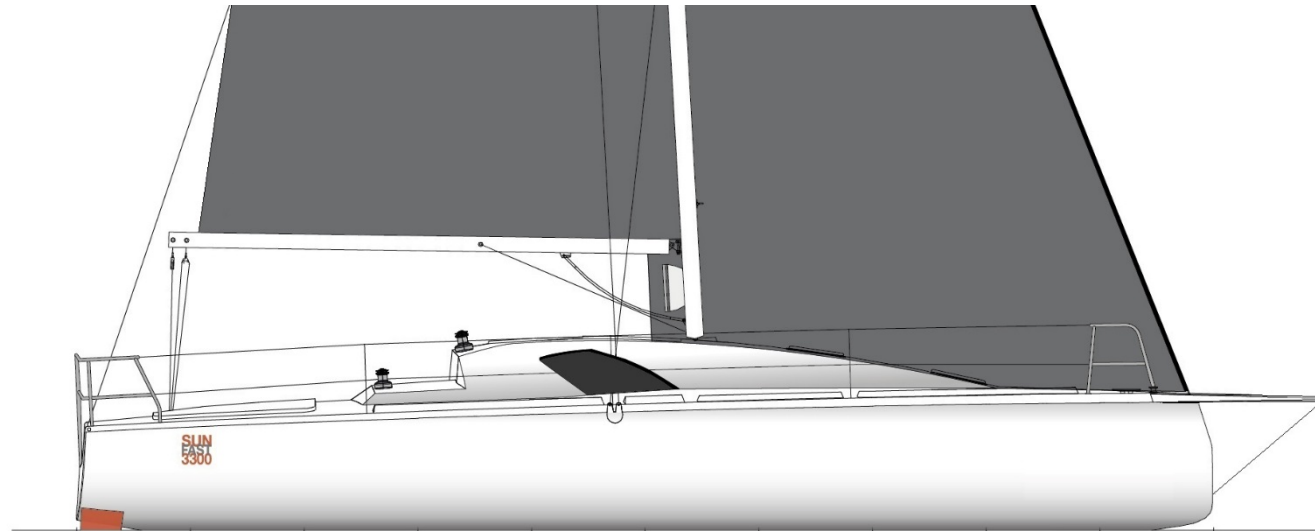

CHARACTERISTICS

Architects	ANDRIEU VERDIER	
Hull length	9.99 m	32' 9"
Overall length (incl .bowsprit)	10.99 m	36' 0"
Max beam	3.40 m	11' 1"
Draft	1.95 m	6' 4"
Displacement	3500kg	7716 lbs
CE Category	A6	
Cabins	2	
Upwind sail area	62.8 m ²	676 Sq.ft
Downwind sail area	141.6 m ²	1524 Sq.ft
Engine	15 HP (11kW)	
Water capacity	100 L	26 US gal
Fuel capacity	50 L	13 US gal
Fridge capacity	40 L	11 US gal
Battery capacity	120 to 240 Ah	

NEW SUN FAST
3300

SUN FAST 3300

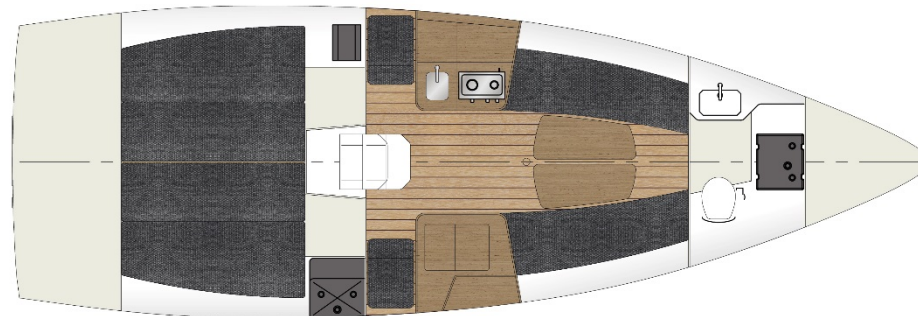
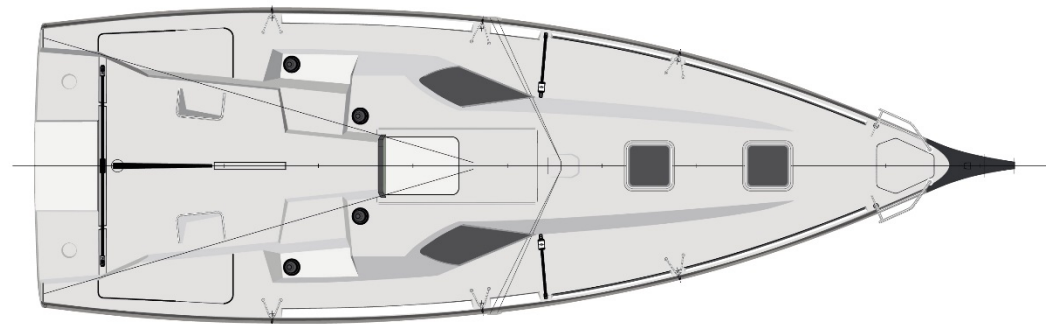
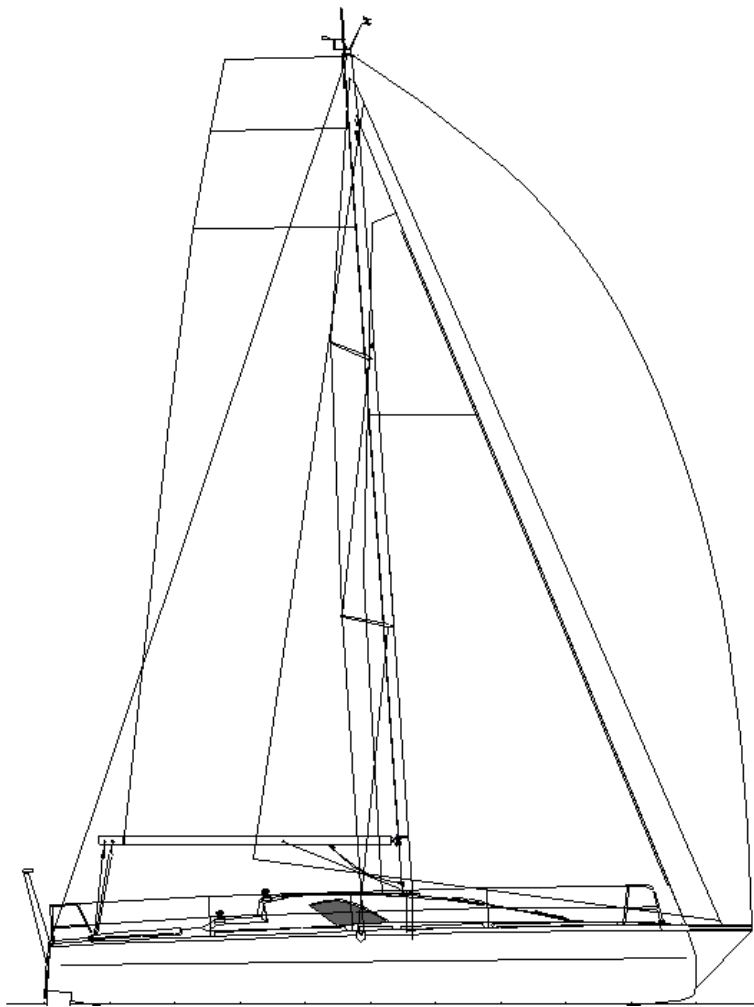

GRUPE BENETEAU

NEW SUN FAST
3300



JEANNEAU

SUN FAST 3300

Velocity prediction :

- Traditional commercial VPPs have trouble when trying to predict performance of the innovative hull shape of the Sun Fast 3300. Nevertheless, mixing results from Verdier's CFD and Andrieu's home-tuned VPP, enabled us to get realistic predictions.
- Initial feedback from sailors confirms our findings, in most cases, except crosswind and planning-compatible conditions, where the boat seems to significantly out-perform the polars.

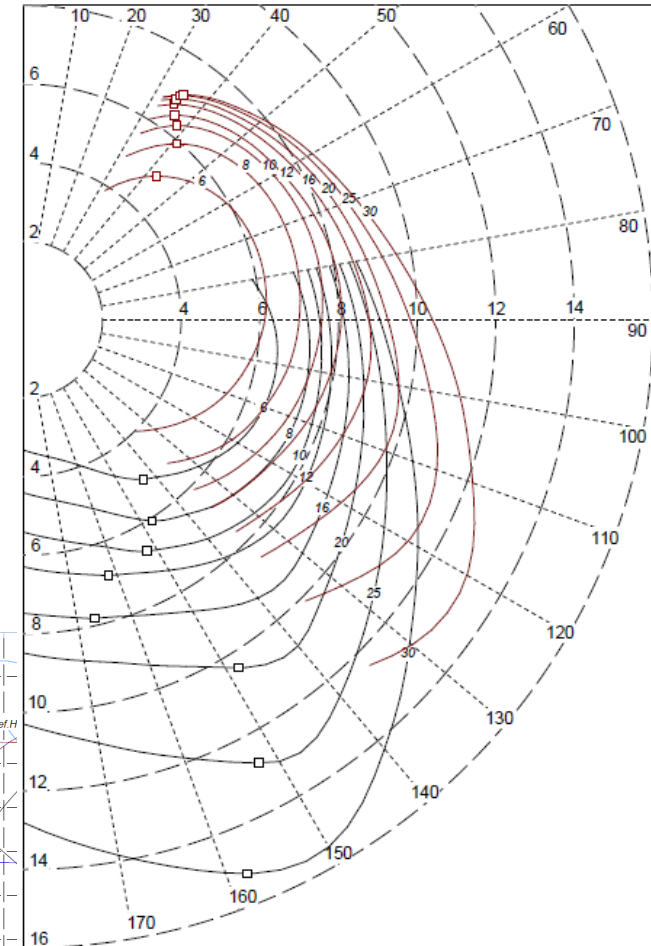
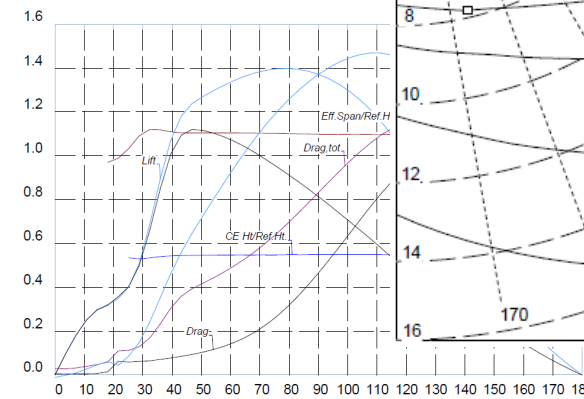
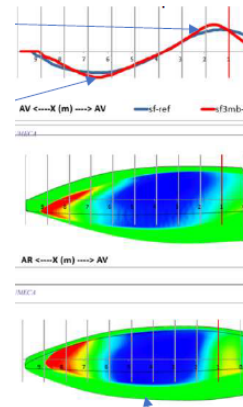
r1111	6.5	20	2	0.00	5.85E+02	3.07E+02	2.78E+02	1.97E+04	-1.61E+05	0.14
r1112	6.5	20	2	-1.00	6.59E+02	3.81E+02	2.78E+02	2.07E+04	-1.51E+05	0.07
r1113	6.5	20	2	1.00	5.49E+02	2.73E+02	2.78E+02	1.85E+04	-1.72E+05	0.21
r2111	11	20	2	0.00	4.50E+03	3.72E+03	7.78E+02	1.64E+04	-2.07E+05	0.05
r2112	11	20	2	-1.00	4.32E+03	3.54E+03	7.78E+02	1.78E+04	-1.95E+05	-0.01
r2113	11	20	2	1.00	4.75E+03	3.98E+03	7.71E+02	1.50E+04	-2.15E+05	0.12
r2121	11	7	0	0.00	4.66E+03	3.86E+03	7.93E+02	5.90E+03	-2.17E+05	
r2122	11	7	0	-1.00	4.36E+03	3.56E+03	8.05E+02	6.51E+03	-2.08E+05	
r2123	11	7	0	1.00	5.12E+03	4.33E+03	7.89E+02	5.47E+03	-2.29E+05	
r3121	4	7	2	0.00	1.38E+02	2.44E+01	1.14E+02	7.90E+03	-1.71E+05	0.10
r3122	4	7	2	-1.00	1.48E+02	3.11E+01	1.17E+02	8.54E+03	-1.59E+05	0.02
r3123	4	7	2	1.00	1.45E+02	3.34E+01	1.12E+02	7.31E+03	-1.85E+05	0.17
r1111	6.5	20	2	0.00	6.99E+02	4.23E+02	2.76E+02	2.08E+04	-1.64E+05	0.01
r1112	6.5	20	2	-1.00	7.82E+02	5.13E+02	2.69E+02	2.13E+04	-1.50E+05	-0.06
r1113	6.5	20	2	1.00	6.87E+02	4.10E+02	2.77E+02	1.99E+04	-1.78E+05	0.08
r2111	11	20	2	0.00	3.49E+03	2.68E+03	8.10E+02	1.80E+04	-1.96E+05	-0.05
r2112	11	20	2	-1.00	3.13E+03	2.36E+03	7.68E+02	1.96E+04	-1.84E+05	-0.10
r2113	11	20	2	1.00	4.17E+03	3.36E+03	8.10E+02	1.71E+04	-2.11E+05	0.01
r3121	4	7	2	0.00	1.74E+02	5.70E+01	1.17E+02	8.03E+03	-1.69E+05	-0.13
r3122	4	7	2	-1.00	2.07E+02	9.11E+01	1.16E+02	8.42E+03	-1.53E+05	-0.11
r3123	4	7	2	1.00	1.74E+02	5.66E+01	1.17E+02	7.68E+03	-1.87E+05	0.04
r1111	6.5	20	2	0.00	6.86E+02	4.10E+02	2.76E+02	2.12E+04	-1.58E+05	0.01
r1112	6.5	20	2	-1.00	7.92E+02	5.20E+02	2.72E+02	2.20E+04	-1.45E+05	-0.06
r1113	6.5	20	2	1.00	6.49E+02	3.70E+02	2.79E+02	2.04E+04	-1.71E+05	0.08
r2111	11	20	2	0.00	3.69E+03	2.88E+03	8.09E+02	1.81E+04	-1.97E+05	-0.06



SUN FAST 3300

Race results :

- The boat was launched in 2019, with full serial production starting only in September, hence relatively few boats could enter regattas...
- But, those who could, achieved impressive results right from the beginning :
 - 2nd out of 22 boats in double-handed IRC in the Spi Ouest France.
 - 1st place and line honours out of 38 boats in the Gascogne offshore race (but DNC due to late certification of the boat).
 - 2nd out of 84 boats in IRC3, in the 2019 Rolex Fastnet Race, 10 days only after touching the water !
 - 5th in the Annapolis ORC distance double-handed race

**2019 RORC Mainseries IRC Three
Rolex Fastnet Race**
Start: Sat 3 Aug 19 13:15:00
Provisional Results

Points	Factored Points	Sail No	Boat	Type of Boat	Owner	Sailed by	Finish Time	Elapsed	Handicap	Corrected	Finishing Place	Comments	Points	Factored Points
100	150	FRA43123	Alpa	JPK 10.30	Jean-Benoit Kolbert	Jean-Benoit Kolbert / Alexis Lecoq	8 Aug - 20:54:34	3-03:21:00	1.029	3-05:06:32	1		100	150
84	141	GBR7933R	Fastrak XII	Jeanneau Sun Fast 3300	Nigel de Quervain Colley	Henry Bomby	8 Aug - 20:54:34	3-07:39:34	1.029	3-09:58:10	2		84	141
85	129	FRA43933	Raging-Bee*	JPK 10.80	Louis-Marie Dusserre	Eric Worbes	8 Aug - 21:52:09	3-08:37:09	1.040	3-11:50:37	4		85	129
83	124.5	FRA53131	Mecanique Expertes	JPK 10.30	Gerard Queriot		7 Aug - 00:09:51	3-10:54:51	1.020	3-12:34:21	5		83	124.5
80	120	FRA43155	Navy Good Trip - Septieme Col	JPK 10.30	Nives Paul Robert		7 Aug - 00:40:57	3-11:25:57	1.024	3-13:06:04	6		80	120
78	117	FRA43907	Alaska	JPK 10.80	Olivier Burgaud		8 Aug - 23:15:57	3-10:00:57	1.038	3-13:07:57	7		78	117
76	114	POL19067	One Way	Sun Fast 3600	Janusz Madej		8 Aug - 23:29:30	3-10:10:30	1.037	3-13:12:56	8		76	114
74	111	FRA13300	Sapristi	Jeanneau Sun Fast 3300	Nigel de Quervain Colley	Alexandre Ozon	7 Aug - 00:29:12	3-11:14:12	1.028	3-13:34:02	9		74	111
72	108	GBR8657L	Belino	Sun Fast 3600	Rob Craigie	Deb Fish	7 Aug - 00:01:46	3-10:46:46	1.041	3-14:10:24	10		72	108
70	105	GBR8936R	Black Sheep	Sun Fast 3600	Trevor Middleton	Jacob Carter	7 Aug - 00:03:47	3-10:48:47	1.045	3-14:32:23	11		70	105
68	102	NED2018	W36 Hubo	W36 Worlds Edition	Erik van Vuuren		7 Aug - 00:11:34	3-10:56:34	1.048	3-14:55:27	12		68	102
66	99	FRA9924	Hey Jude	UJ120	Philippe Girardin		7 Aug - 00:46:57	3-11:31:57	1.041	3-14:57:26	13		66	99
65	97.5	FRA34938	Nami	A35	Fredric Levrel		7 Aug - 02:52:13	3-13:31:13	1.024	3-15:42:31	14		65	97.5
64	96	FRA39933	Wooloomooloo Too	Sun Fast 3600	Philippe Acustin	Philippe Lejeune	7 Aug - 01:34:00	3-12:19:00	1.041	3-15:46:25	15		64	96
63	84.5	GBR1355R	Lutote	Swan 55 Yawl	Ben Morris		7 Aug - 03:37:40	3-14:22:40	1.020	3-16:06:19	16		63	84.5
62	83	FRA34983	Decatur	A35	Gebr. de Zeeuw		7 Aug - 03:38:48	3-14:23:48	1.021	3-16:12:40	17		62	83
61	81.5	GBR2729R	Lillyfish	Sun Fast 3600	David Richards	Stacey Clark & Andrew Bassett	7 Aug - 02:09:44	3-12:54:44	1.045	3-16:44:00	18		61	81.5
60	80	GBR704R	Phrosophie IV	First 40.7	Nicolas Gaumont-Prat		7 Aug - 02:21:00	3-13:06:00	1.043	3-16:45:33	19		60	80
59	88.5	GER1950	Eian	Swan 48	Harald Baum	Daniel E. Baum	7 Aug - 02:49:58	3-13:34:58	1.039	3-16:55:14	20		59	88.5
58.5	87.75	GBR4790L	Joy	JPK 10.10	Peter Butlers		7 Aug - 06:10:44	3-16:55:41	1.004	3-17:17:05	21		58.5	87.75
58	87	GBR765R	Oratio	Sun Fast 3600	Nick Martin		7 Aug - 04:13:21	3-14:55:21	1.030	3-17:34:54	22		58	87
57.5	86.25	NL7791	LYS Jan	UJ109	Sreg Naamlyth	Nikki Henderson	7 Aug - 06:21:37	3-17:06:37	1.010	3-18:00:05	23		57.5	86.25

Design Insight

Stonking debut

Dramatic looking, precisely tailored to its target market, well executed and winning as soon as it hit the water...

There can be few brighter debuts for a new 33-footer than being thrown into the fiercely competitive Rolex Fastnet Race. To pile on the pressure, Fastrak XII, one of the new Jeanneau Sun Fast 3300s, had only been launched 10 days before the start.

While Fastrak XII was in the capable hands of experienced offshore sailors Henry Bomby and Hannah Diamond, they were as new a partnership as the boat. And yet 80 hours later Bomby and Diamond had delivered an impressive performance finishing second overall in the 6.1 boat double-handed fleet. But that was just the start. They were also second overall out of 84 boats in IRC3, a fleet that included fully crewed and double-handed entries.

Their results had been a success all round. Bomby and Diamond had proved themselves as an impressive offshore duo, while for Jeanneaux, success in the world's biggest offshore race provided further validation of a new design that had



can be no doubt at all that these new boats are a big step forward.' A glance back at some of the boat data aboard Fastrak XII from the race provides even further evidence with spreads well into 20kts on the fast reach back from the mark.

'We know just from the demo sails we've been doing that she will sit easily at 15kts in 20-25kts of breeze. This alone is a step up from the previous generation,' continues Colley. 'But what has surprised us even more for a boat that weighs the same as the Sun Fast 3200 is how she doesn't need a wave to surf down to get up onto the plane, she just seems to climb there herself on flat water.'

Jeanneau's latest Sun Fast 3300 has already proven itself to be an even

took 1st, 2nd and 4th while in the double-handed fleet. Jeanneau Sun Fast 3300 has already proven itself to be an even



JEANNEAU

SUN FAST 3300

Offshore abilities:

- Based on extensive experience and feedback from hundreds of Sun Fast owners worldwide, the 3300 was designed from the beginning for Offshore sailing.
- Targeted races include the double-handed Transquadra, the Fastnet race, Giraglia, Sydney-Hobart, or the new UNCL short-handed IRC Transat...
- Best-in-class naval architects: Daniel Andrieu collaborated with offshore specialist Guillaume Verdier (Ultimates, Imocas, Class 40, Minis...).
- Compatible with single-handed and full crew regattas, but focused on double-handed use.
- Protected cockpit, seaworthy and ergonomic layout (symmetrical cabins, lee-clothes, handrails, rest-seats...)
- CE category A, OSR Cat.2 compliant.



SUN FAST 3300

Mixed double-handed:

- Manœuvres are faster with four arms, but the boat can easily be sailed singlehanded, allowing one of the crew to concentrate on the strategy, navigation while the other operates the boat.
- Reasonable sail area and properly sized deck hardware to minimise the physical efforts and required strength.
- Real ergonomic spaces for two crew in the cockpit.

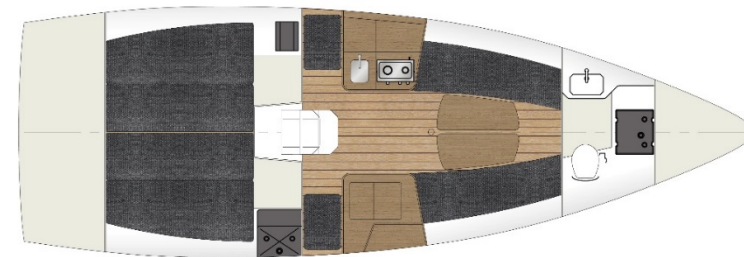

SUN FAST 3300

Technical approach:

- Many key points were thoroughly investigated during the development phase, to better take into account the offshore sailor's needs :
- Most of our clients use symmetrical spinnakers for the Transquadra and inshore races, but offering a real asymmetric alternative can change the game offshore, and simplify the manoeuvres. The Sun Fast is available in both configurations...
- The same applies for the rig: a carbon mast is of course available, but the aluminium spar is the standard specification. This cost-effective solution gives better weight consistency, and is much more sustainable.
- The boat is also water ballast compatible. We don't feel it would be a real plus for Olympic purposes, but they could simulate an additional crew in case of single-handed training.
- Lots of effort was focused into ensuring that the Sun Fast 3300 is perfectly balanced. Helmsman's pleasure was of course part of the objective, but this was primarily done to aide any autopilot to steer the boat with very low consumption.
- Other studies were researched and could be further described and discussed...

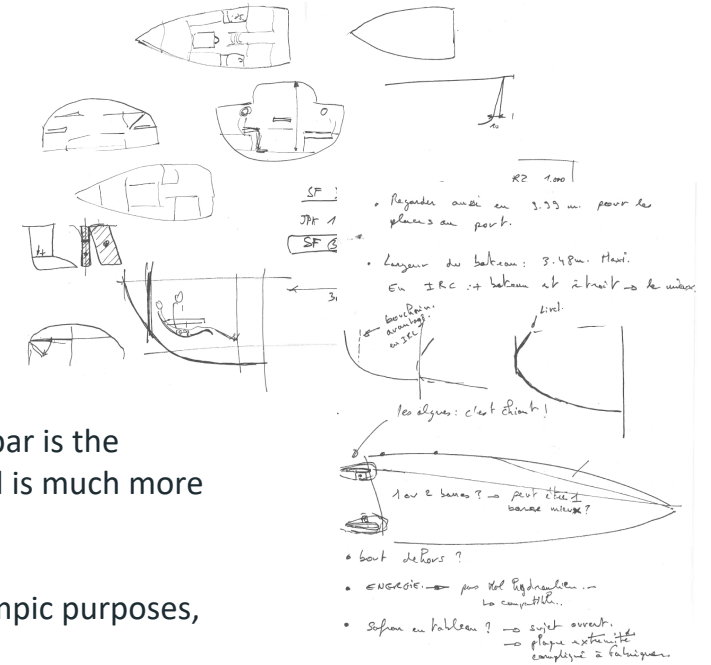

SUN FAST 3300

Distribution:

- Worldwide network : more than 250 Jeanneau dealers, in 80 countries on 5 continents..
- Extensive support : Service, aftersales, spare parts, financing, advice, Jeanneau proposes much more than boats !
- More than 50 boats sold in 6 month time, in 11 countries and 4 continents : commercial success is well on its way...

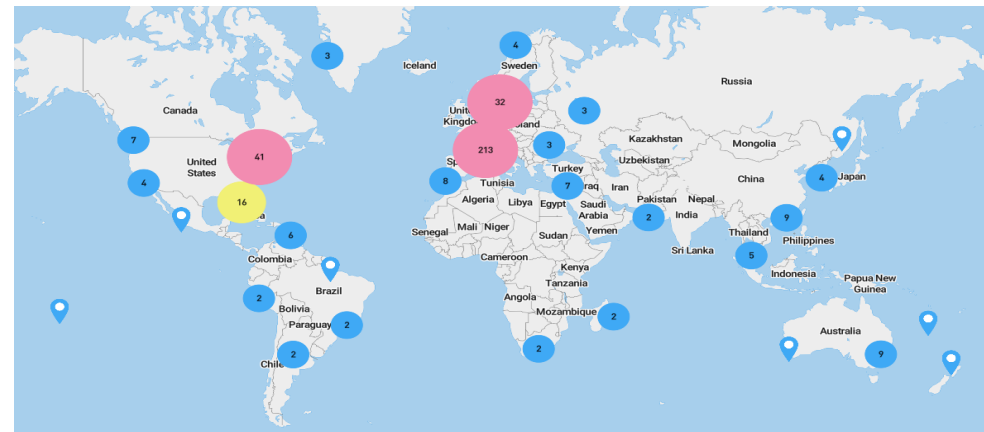

SUN FAST 3300

Events :

- Jeanneau is very keen onto keeping close and regular contact with its customers and final users, we feel this is the most efficient way to get real on-the-water feedback, and follow market trends.
- In the Sun Fast range, where the clients are passionate racers and the fleets are very active, this translates into a variety of events, from dedicated races to in-room tutorials held by offshore specialists.
- The “Sun Fast Challenge” was created in 2015, it is a yearly ranking of the boats, based on their results over the season’s races. It pushes the Sun Fast owners to enter and finish a maximum of races, and has proven very successful.
- The challenge has always had with specific ranking for double-handed boats and Jeanneau will continue to push the mixed-doubled teams in 2020 with dedicated prizes.
- In 2019, Jeanneau also launched a “Sun Fast World Cup” to invite a fleet of Sun Fasts to the same starting line. The event, sailed in La Trinité-sur-Mer, was a great success. 2020 Sun Fast World Cup will take place in Cowes, and it is anticipated that the coming years will be raced on the Olympic racecourse.



GROUPE BENEteau



SUN FAST 3300

Awards:

- Elected: Sailing World Boat of the Year (USA).
- Nominated: European boat of the Year 2020 (EU).
- Nominated: British Yachting Awards 2019 (UK).
- Nominated: World Sailing 2019 Goslings Boat of the Year Award.



SUN FAST 3300

Testimonial:

We were amazed at how quickly we were able to get out on the water racing with only 4 days of commissioning and sea trialling. We feel the "turnkey" aspect of the Sun Fast 3300 is a key asset in its selection for the Mixed Offshore equipment at the Paris 2024 Olympics. Thanks to its simplicity and limited accommodation, the boat can easily be reproduced to a consistently high standard to make a strong one design.

In the Fastnet we achieved 2nd place in IRC Double-handed & IRC 3, it is clear therefore the boat performs very well on IRC, which again would give the Sun Fast 3300 an afterlife and resale value after the Olympics.

The boat is a joy to sail, very similar to a Figaro in layout. It is easy to trim all the sails from where you sit and drive which is fundamental to shorthanded offshore sailing, and a necessity if there will be no pilot. The boat is well balanced in the breeze, on the way back



from the Fastnet Rock we achieved 23+kts boat speed surfing down waves which was impressive for a 30-foot boat that was still in the factory two weeks prior. We had no breakages during the race other than sails.

Next season, in Great Britain the winner of the IRC 2H Mixed Crew in the RORC Channel Race will be selected to go to the World's in October next year. Henry has chosen to compete in the Sun Fast 3300 due to its low cost and ability to compete well in IRC races. We feel it's a top choice for winning the British trials!

This boat is great fun, manageable, simple and noticeably fast in chop

Hannah Diamond & Henry Bomby.



© Carlo Borlenghi

SUN FAST 3300

Testimonial:

After years of combined racer and sailmaker experience, I decided to go back to offshore sailing, and enter the 2021 double-handed Transquadra race.

During the last 4 seasons, I had raced a Sun Fast 3600 in the Mediterranean.

The choice of the new 3300 was led mainly by the perfect balance Jeanneau manages to achieve between performance, rating, ease of use and durability.

Investments for this type of programme are high and demanding, for the 3 years campaign I plan, I absolutely wanted a long lasting, modern and performant boat, as my previous Sun Fast had been...



When I first tried the 3300, I was amazed with the speeds my wife and myself could achieve, with a strong feeling of ease and safety. The boat is almost as fast as the 3600 (even faster in some conditions) and much easier to handle without full crew. She feels and performs more like a small Open 40 than a typical IRC boat.

It is also impressive to see how innovative the boat is : deck and interior layouts are simple and neat, but they bring modern high-end raceboats concepts and solutions into the non-professional, serial production field.

I really enjoy every moment I spend onboard the Sun Fast 3300, and I look forward to race her across the Atlantic ... !

SUN FAST 3300

Ken Read and Jeanneau America Partner to Promote Double-handed Racing in North America:

Jeanneau America announced today that world-renown American yachtsman and North Sails President Ken Read will campaign the new Jeanneau Sun Fast 3300 in the double handed division of the 2020 Fort Lauderdale to Key West Race along with navigator Suzy Leech. The plan is to continue with a schedule that includes other events on the double handed offshore sailing calendar in 2020, a discipline that is growing in popularity especially after the announcement of a mixed gender double-handed offshore class in the 2024 Olympics.



From the drawing board of Daniel Andrieu and Guillaume Verdier, the Sun Fast 3300 is the all-new offshore race boat from Jeanneau. Designed for short-handed teams who are looking for a high performance platform, the boat is capable of long distance racing competitively under modern rating rules.

“It’s an exciting move for us,” said Nick Harvey, President of Jeanneau America. “Short-handed sailing has been growing in interest globally, and Jeanneau is proud to develop a production boat that is capable of taking those sailors where they want to go.”



SUN FAST 3300

Architects viewpoint :

Over the past 15 years, as the designer, I created a unique family of double-handed racing boats for Jeanneau: the Sun Fast range.

When Jeanneau asked me to design the most recent model, I suggested that we collaborate with the world renown designer Guillaume Verdier, to combine our talents and experiences to design for Jeanneau a new Sun Fast around 10 meters.

From the origin of the project, Jeanneau included in the specifications the Double-handed Offshore Races as a main goal, and asked us to think in depth about what would be the right criteria for the boat would be THE boat of the coming years.

Here is what we come up with:

- *A very stiff and seaworthy boat. In double-handed racing, it is important to sail in safety, whatever the wind and sea conditions. This makes sense today when you know that in Marseille during the Olympic Games the probability of encountering winds between Force 6 and Force 8 is 10 days per month, or 1/3 of the time...*
- *A very fun and fast boat able to reach and exceed 20 knots, a guarantee of thrills and impressive live videos.*
- *A boat easy to sail, with a simple deck Layout, dedicated to a wider market, which is in the Jeanneau DNA.*
- *A simple and efficient sail plan with easy handling.*
- *Safety First. The boat is CE approved A Design Category and World Sailing Structural Approval.*
- *An ergonomic inside layout for double handed sailing.*
- *Last, but not Least, the new Sun Fast 3300 has a futurist look, in line with what all sailors dream of!*



SUN FAST 3300

Architects viewpoint :

The Sun Fast 3300 is the logical continuity / maturation of the Sun Fast 3200-3600. It was an interesting mix of culture: Our team coming from the Offshore sailing together with Daniel 's huge experience of the IRC.

But rule constraints are like any other design variables: We integrated them and got to find together the smartest possible way to fit those in an accessible double-handed offshore racer.

The New Sun Fast consequently got a click more righting moment capability without endangering much the low wetted area at low heel angles. This came possible with a lot of Computational Fluid Dynamics iterations helping us at finding tricks.

The keel stiffness and weight distribution got particular attentions allowing us to improve performance without penalties. Finally the ergonomic design of the cockpit as well as the sail plan development got an incredible attention for maximizing the power while improving crew efficiency.

The reality is that we enjoyed designing this boat, and to my opinion it is the key to success.



Guillaume Verdier



THANK YOU

WE REMAIN AVAILABLE FOR
FURTHER INFORMATION...